

UWAGI:

1. Wszystkie części żelazne są ocynkowane ogniowo
2. Wszystkie wymiary podano w milimetrach



GUANGDONG HENVCON ELECTRIC POWER TECHNOLOGY CO.,LTD

Tolerancja		Łącznik dwuwidlasty skręcony TYP: Z-7			
≤30mm	±1.5mm				DATE:2022-10-19
>30mm	±5%	Z-7	A		
MAX.	±10mm				
DRAWING		L.M.H			
VERIFY		ZH.J			
RATIFICATION		ZH.J			

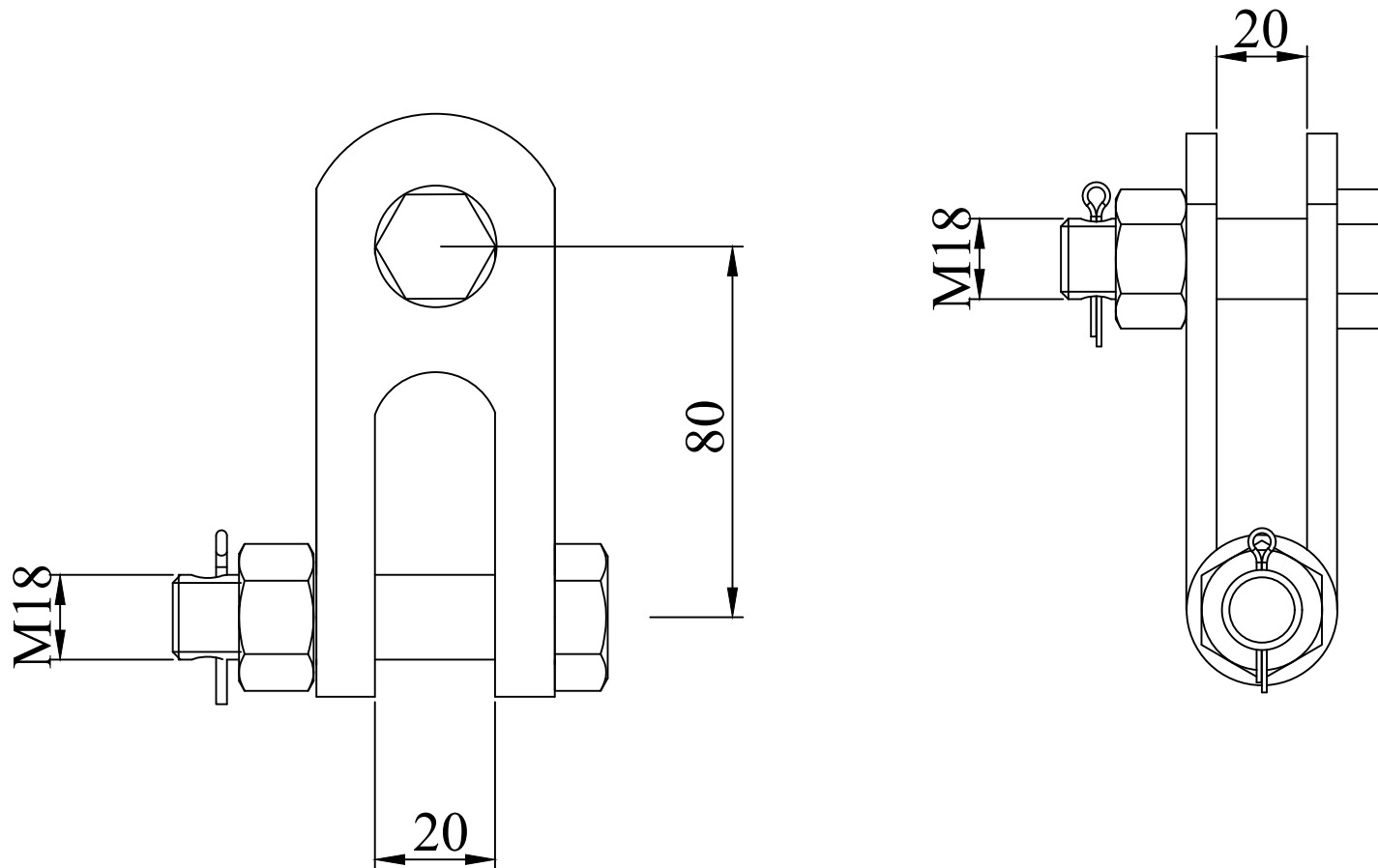

UWAGI:

1. Wszystkie części żelazne są ocynkowane ogniowo
2. Wszystkie wymiary podano w milimetrach

ENECONSULTING

GUANGDONG HENVCON ELECTRIC POWER TECHNOLOGY CO.,LTD

Tolerancja		Łącznik dwuwidlasty skręcony TYP: Z-10			
≤30mm	±1.5mm				DATE:2022-10-19
>30mm	±5%	Z-10	A		
MAX.	±10mm				
DRAWING		L.M.H			
VERIFY		ZH.J			
RATIFICATION		ZH.J			

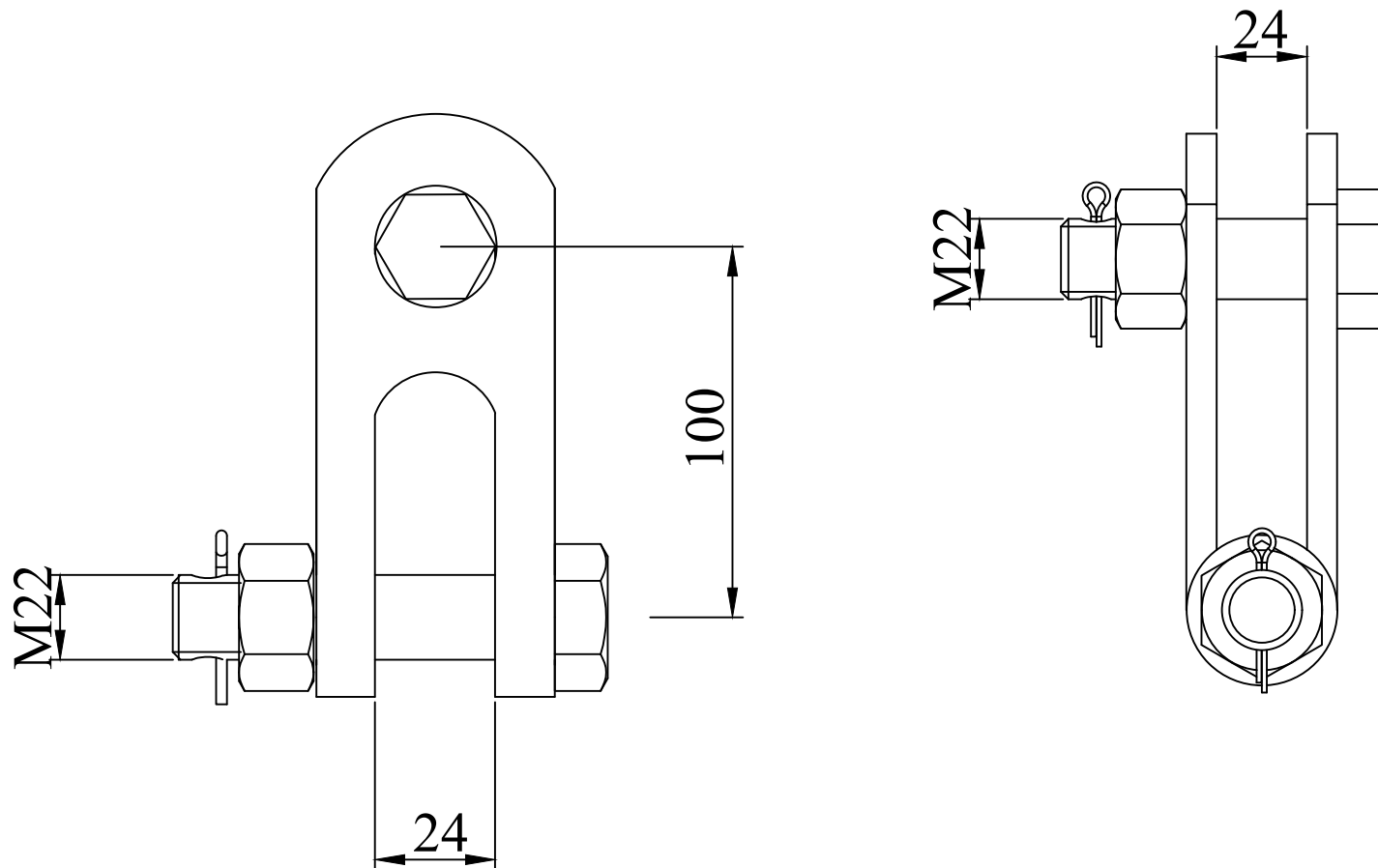

UWAGI:

1. Wszystkie części żelazne są ocynkowane ogniowo
2. Wszystkie wymiary podano w milimetrach

ENECONSULTING

GUANGDONG HENVCON ELECTRIC POWER TECHNOLOGY CO.,LTD

Tolerancja		Łącznik dwuwidlasty skręcony TYP: Z-12		
≤30mm	±1.5mm			
>30mm	±5%			
MAX.	±10mm			
DRAWING		L.M.H	Version	Z-12
VERIFY		ZH.J		
RATIFICATION		ZH.J		